

Creo® Piping and Cabling Extension

ACCELERATE YOUR PIPING AND CABLING DESIGN PROCESS

Traditional mechanical products are becoming more and more complex due to their increased reliance on electrical and hydraulic technology. Control systems are also advancing at an astonishing rate, forcing product designers to pay much more attention to electrical and fluid requirements.

As designers move to take advantage of the IoT and sensors are added, the requirements for piping and cabling increase. All of this means that designers are now dealing with more complicated piping and cabling routings, which traditionally have taken a low priority during product design.

To be successful, designers must make electrical and fluid design a higher priority and a more integral part of the detailed design process. Yet, as product complexity increases and schedules continue to shrink, where will you find the time and tools to design these increasingly complex routings?

Creo Piping and Cabling Extension (PCX) is the perfect 3D solution because it supports all types of industries and styles of piping and cabling, so you can streamline and accelerate the entire design process. Whether you're designing products with a complex web of cables and harnesses, hydraulic or pneumatic hoses, high and low pressure tubing, copper work, or even large bore pipes, Creo PCX can handle the job, no matter how intricate.

Key benefits

- Capture and document schematic information and manufacturing documentation
- Minimize errors and reduce time-consuming tasks by automating the capture of all relevant system information, such as the schematic design, virtual prototype, or manufacturing documentation

- Fully automate your routing so you can quickly determine the optimum path for manufacturing, cost, and serviceability
- Ensure design rules and schematic logic rules are enforced through specification-driven design
- Increase design speed through the reuse of standard symbols, connectors, and fittings contained in a customizable library
- Reduce costs and design time by eliminating the need for physical prototypes, made possible through virtual interference checking and automated manufacturability verification
- Enable cost-effective manufacturing through accurate documentation, such as isometric drawings, bend tables, and BOMs

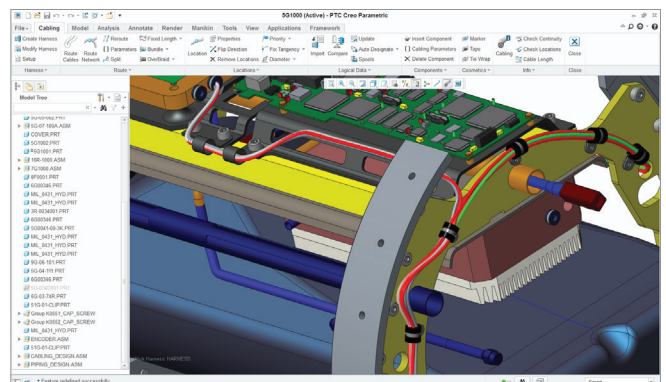

Accelerate 3D routed systems design

A time-consuming, error-prone process

Determining the routes of pipes and cables can be a difficult, time-consuming task. Beginning with the creation of a physical prototype and then manually routing the pipes through it, this long, tedious process is typically error-prone. Because of the time and effort involved, the engineer often must accept the first route that works — not necessarily the optimal one.

Even worse, when an engineering change is made to the design, it means the engineer must start over by recreating the physical prototype and rerouting the cabling or piping — thus wasting valuable time. Additionally, most companies that create the cabling prototypes don't document the cabling routes, which make it difficult to service these products.

To solve these issues, a company will often send a service engineer to the field, which can be very costly. With Creo PCX, these problems can be avoided.

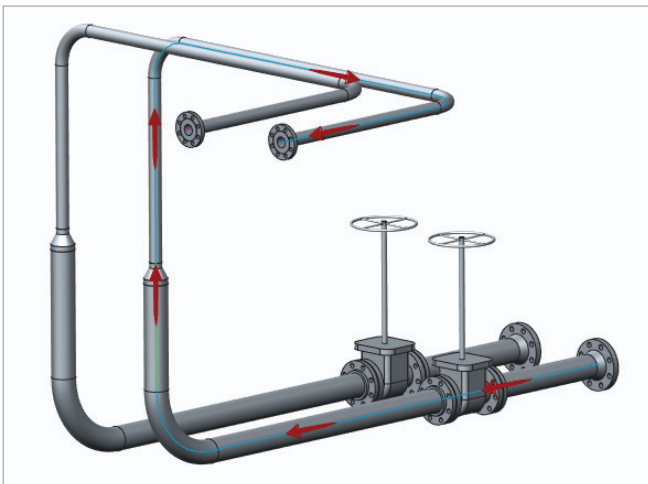

With Creo PCX, you can immediately determine the best piping routes between even the most complex systems.

Creo Harness Manufacturing Extension (HMX)

Creo HMX dramatically reduces the time to create documentation and the user expertise required to create standardized manufacturing documentation. At a touch of a button and at any stage of the design process, manufacturing documentation can be created for purchasing to obtain the most competitive manufacturing cost.

Key benefits:

- The intuitive, easy-to-use user interface enables any engineer to create manufacturing documentation to a pre-defined standard
- New streamlined solution improves user efficiency and productivity
- Easily accommodate late-stage changes to your engineering design faster and with less frustration
- Documentation is automatically created to a preconfigured standard

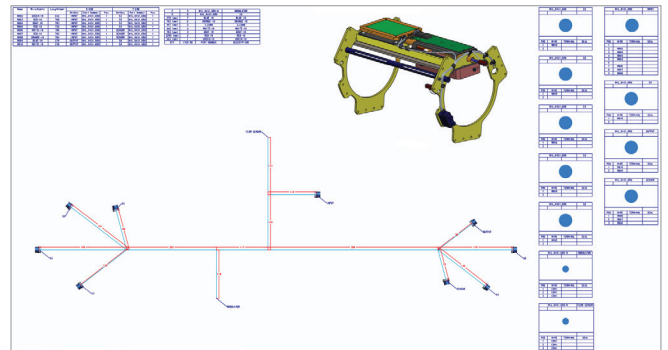

Creo Harness Manufacturing Extension (HMX).

Creo Schematics™ Lite

Creo Schematics Lite provides all the capabilities that designers of piping and cabling systems need to easily capture the logical connectivity information in 2D schematics. Included with Creo PCX, Creo Schematics Lite is an introductory schematic tool that can grow with your design needs. Advanced capabilities, such as design reuse support, multiuser capabilities, customization for design automation, and central catalog, can be added optionally.

Capabilities and specifications

- Piping diagrams
 - Supports 2D pneumatic, hydraulic, process flow (PFD), PI&D, and HVAC
- Cabling diagrams
 - Supports 2D Block Interconnect, Circuit, and Wiring Interconnect design
- Design reuse
 - Central Design Catalog
 - Data tables
 - Import legacy Pro/DIAGRAM data
- Electrical simulation
 - Seamless integration to E-Simulate
 - E-Simulate Lite is available only with the full version free of charge
 - E-simulate standard can be purchased from www.virtual-interconnect.co.uk
- 3D CAD support
 - Drives Creo 3D piping and cabling designs
 - Drives other 3D CAD routed systems designs

Piping design

Creo PCX enables designers to fully automate the pipe-routing process. Designers no longer have to build physical prototypes and struggle through the trial-and-error process; they can determine — virtually — the optimal paths of the pipes in the model. In addition, designers can create rules that are based on company best practices or corporate policies. By establishing rules, the software can then verify that this optimal path is compliant with established manufacturing rules. Plus, designers have access to a library of standard fittings, which can be reused from product to product, reducing time-to-market and increasing designer productivity.

The fully associative nature of Creo Parametric™ ensures that the pipe routing — and accompanying documentation — will automatically update whenever a design change is made to the model.

Accurate and efficient routing of pipelines and fittings:

- Automate the creation of 3D routes from 2D schematics
- Leverage intelligent schematic information for design reuse
- Create piping routes faster using lightweight representations
- Automate fitting placement based on schematic information while adhering to design rules
- Concurrently route pipelines in a multi-user environment
- Asynchronous piping settings let you change the pipe shape, bend radius, corner type, or line stock on the fly
- Manipulate existing pipelines easily with an intuitive dashboard user interface, shortcut menus, and dynamic dragging

Comprehensive suite of tools for fitting insertion:

- Search for fittings that meet the specifications of your project so you only work with the correct pipes and fittings
- Automatically display the correct fittings based on schematic information
- Automate the placement of gaskets, flanges, elbows, and other components
- Preview the placement of the object to achieve full control over the insertion

Reinforce predefined rules through violation detection:

- Maximums and minimums of the bend radius
- Minimum branch separation and branch angle
- Placement and missing fittings
- Flow violations

Complete control over flow directions:

- Automatically set initial flow direction based on routing
- Easily change flow direction for a series or pipe-line
- Automatically reverse directional fittings with change of flow direction

Verification of piping routes to prevent errors:

- Electronically verify 3D data — compared to logical data — to detect missing fittings and other common missteps
- Check for design rules, such as missing gaskets, in the model
- Create automatic cut lists, bend tables, and BOMs

Easily extract information from the design for outputs:

- Bill-of-Materials
- Bend machine and detailed fitting reports available
- Schematic consistency check
- Communication of piping system layout and detail in the form of isometric, installation, and pipe spool drawing
- Output to CNC bending machines

Cabling design

Creo PCX gives you the power to extract logical information from 2D schematics while automating your 3D cable routing. Not only can you determine a working route quickly, but you can easily find the optimal route that won't interfere with the design. Plus, since it's a Creo Parametric model, it has the advantage of full associativity; that means any change made to the model is automatically reflected in the cabling routes. With fewer (if any) physical prototypes and shorter design cycles, you'll save significant time and money.

Capabilities and specifications:

- Improved Bundle Representation
- Realistic depiction of shrink-wrap tubing with bundle transitions

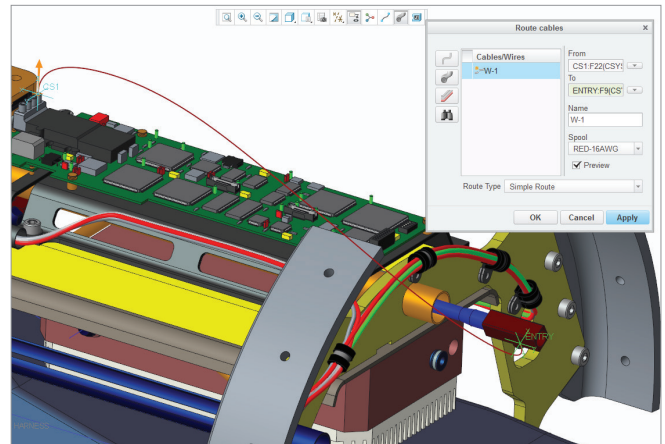

Determine the connections either manually or from logical information. Creo PCX automatically generates a simple path which then enables the user to find the optimum path faster.

Automate cabling routing

Improved realism in bundle display and better downstream use of cable design information

- Model tree with extensive information cables, cable contents, and wires
- Ability to select a single wire
- Highlights in display
- Wire parameters displayed

Electronically document the entire design process

- Automatically flatten 3D harnesses for manufacturing documentation

Automate the creation of fully defined 3D harnesses

- Automate harness routing by referencing 2D logical information
- Digitally define complete 3D harnesses with connectors and components
- Modify cabling networks faster with drag handles and on the fly editing capabilities
- Automatically route ribbon cables and cable shields
- Create ribbon cables faster using automated capabilities
- Implement engineering changes to the assembly, confidently knowing that Creo Parametric associativity will automatically update the cabling routing
- Calculate mass properties and perform clearance evaluations

Concurrently route harnesses in a multi-user environment automate the flattening of 3D harnesses for manufacturing

- Quickly flatten 3D harnesses to create accurate 2D harness documentation with intelligent dimension, BOMs, and pinouts
- Create fully associative, customizable lists and tables containing all information necessary to create the harness
- Detail the flat harness drawing with parametric notes, dimensions, symbols, and tables

Enable more effective enterprise communication

- Produce fully associative detail drawings for 3D and flattened harnesses
- Create complete documentation, including intelligent dimensions, BOMs and pinouts
- Share schematics, documentation, and harnesses with the entire product development team using the Creo View™ visualization tool

The Creo Advantage

Creo is a 3D CAD solution that helps you build better products faster by accelerating product innovation, reusing the best of your design and replacing assumptions with facts. Go from the earliest phases of product design to a smart, connected product with Creo. And with augmented reality in each seat of Creo, everyone can easily visualize your designs. In the fast-changing world of the Industrial IoT, no other company can get you to substantial value as quickly and effectively as PTC.

Language support

- English, German, French, Italian, Spanish, Japanese, Chinese (Simplified and Traditional), Korean, and Russian.
- Creo Schematics Lite is available in English, French, German, Japanese, and Simplified Chinese

Platform support and system requirements

Please visit the [PTC support page](#) for the most up-to-date platform support and system requirements.

For more information, visit:

[PTC.com/product/creo](https://www.ptc.com/product/creo) or contact your local sales representative.

© 2018, PTC Inc. (PTC). All rights reserved. Information described herein is furnished for informational use only, is subject to change without notice, and should not be taken as a guarantee, commitment, or offer by PTC. PTC, the PTC logo, and all PTC product names and logos are trademarks or registered trademarks of PTC and/or its subsidiaries in the United States and other countries. All other product or company names are property of their respective owners. The timing of any product release, including any features or functionality, is subject to change at PTC's discretion.

J10523-Creo-Piping-Cabling-Extension-EN-1117